

Abstract

The paper describes the application of a new *Water Accounting Plus* (WA+) framework to produce spatial information on water flows, sinks, uses, storages and assets, in the Indus Basin, South Asia. It demonstrates how satellite-derived estimates of land use, land cover, rainfall, evaporation (E), transpiration (T), interception (I) and biomass production can be used in the context of WA+. The results for one selected year showed that total annual water depletion in the basin (502 km^3) plus outflows (21 km^3) exceeded total precipitation (482 km^3). The deficit in supply was augmented through abstractions beyond actual capacity, mainly from groundwater storage (30 km^3). The “landscape ET” (depletion directly from rainfall) was 344 km^3 (69 % of total consumption). “Blue water” depletion (“utilized flow”) was 158 km^3 (31 %). Agriculture was the biggest water consumer and accounted for 59 % of the total depletion (297 km^3), of which 85 % (254 km^3) was through irrigated agriculture and the remaining 15 % (44 km^3) through rainfed systems. While the estimated basin irrigation efficiency was 0.84, due to excessive evaporative losses in agricultural areas, half of all water consumption in the basin was non-beneficial. Average rainfed crop yields were 0.9 t ha^{-1} and 7.8 t ha^{-1} for two irrigated crop growing seasons combined. Water productivity was low due to a lack of proper agronomical practices and poor farm water management. The paper concludes that the opportunity for a food-secured and sustainable future for the Indus Basin lies in focusing on reducing soil evaporation. Results of future scenario analyses suggest that by implementing techniques to convert soil evaporation to crop transpiration will not only increase production but can also result in significant water savings that would ease the pressure on the fast declining storage.

1 Introduction

The aim of water accounting is to track inflows and outflows, assets, liabilities, stocks and reserves for a particular area over a period of time. Outcomes are essential for

HESSD

9, 12921–12958, 2012

Basin-wide water accounting using remote sensing data

P. Karimi et al.

Title Page

Abstract

Introduction

Conclusions

References

Tables

Figures

◀

▶

◀

▶

Back

Close

Full Screen / Esc

Printer-friendly Version

Interactive Discussion



both current and future water management decisions. Water accounting principles are described in detail by Godfrey and Chalmers (2012). Availability of data on water flows, and consumption is a major constraint for reliable accounting in world river basins. For this reason, data intensive water accounting frameworks such as the United Nations System for Environmental and Economic Accounting for Water (SEEA) (UN, 2007), which tracks water withdrawal by different sectors, are not commonly implemented (Karimi et al., 2012b).

Water accounting Plus (WA+) (Karimi et al., 2012a) presents water accounts of river basins in four “sheets” including (i) a “resource base sheet”, (ii) a “consumptive use sheet”, (iii) a “productivity sheet”, and (iv) a “withdrawal sheet”. The resource base sheet gives information on water volumes. Water supply and water depletion and consumption processes are presented. The consumptive use sheet shows how beneficial the water consumption is. The productivity sheet shows links between water consumption and biomass production, carbon sequestration, crop production and water productivity. The withdrawal sheet provides information on water withdrawals and reuse. Every sheet has a set of indicators that summarizes the overall water resources situation. WA+ explicitly recognizes the influence of land use on the water cycle. To provide the link between water balance, land use and water use, it groups land use classes with common management characteristics including “Conserved Land Use” (CLU), “Utilized Land Use” (ULU), “Modified Land Use” (MLU), and “Managed Water Use” (MWU).

The large transboundary Indus Basin with many challenging water problems (Qureshi, 2011) was selected to illustrate the WA+ applications. The fundamental data on water sources and flows in basins such as the Indus Basin are either missing or not accessible. The size of the basin, budget constraints and its transboundary nature hamper the establishment of a comprehensive measurement network. For example, in the Indus Basin less than four rain gauge stations are available per 10 000 km². The situation is worse for in-situ soil moisture and evapotranspiration measurements. Information on land use and crop rotation systems is similarly scant. Available databases are old, coarse and do not cover the entire basin. Satellite-derived data can improve

Basin-wide water accounting using remote sensing data

P. Karimi et al.

Title Page

Abstract

Introduction

Conclusions

References

Tables

Figures



Back

Close

Full Screen / Esc

Printer-friendly Version

Interactive Discussion



of groundwater, the other major challenges that the basin faces include the increasing gap between supply and demand, water logging in poorly drained areas, climate change impacts, environmental degradation, soil salinization, and above all, political disagreements among riparian countries (Qureshi, 2011).

3 Data

3.1 Land use and land cover

Land Use and Land Cover (LULC) affect the water balance, as well as the benefits and services for society and for the environment. Spatially distributed information on LULC is thus the key information required by WA+. Whereas LU relates to a specific use of land (e.g. production pasture), LC describes the physical state of that particular land surface (e.g. grass). There are a number of global and regional land cover databases based on remotely sensed data using different algorithms (e.g. Bartholomé and Belward, 2005; Bontemps et al., 2010; Friedl et al., 2010; Thenkabail et al., 2005). These products mainly provide LC data and information related to LU is limited.

An existing LULC map of the Indus, developed by Cheema and Bastiaanssen (2010), was used for this study. It is based on the seasonal phenological variations of 27 classes from temporal profiles of NDVI from SPOT-Vegetation. Different crop classes were identified and verified through ground truth campaigns. The LULC classes were then re-grouped into four major clusters that differed in terms of water management: Conserved Land Use (CLU), Utilized Land Use (ULU), Managed Land Use (MLU) and Managed Water consumption (MWU). The area under CLU is 83 081 km², ULU is 612 184 km², MLU is 174 100 km² and MWU is 278 279 km².

WA+ uses LU information on (i) irrigated areas, (ii) rainfed areas, (iii) forests, (iv) savanna and (v) pastures. Since WA+ treats natural water bodies differently from man-made reservoirs, the LC class “water bodies” is divided into LU (i) natural water bodies and (ii) reservoirs. In WA+, natural water bodies are classified as Utilized

Basin-wide water accounting using remote sensing data

P. Karimi et al.

Title Page

Abstract

Introduction

Conclusions

References

Tables

Figures

◀

▶

◀

▶

Back

Close

Full Screen / Esc

Printer-friendly Version

Interactive Discussion



Land Use whereas reservoirs belong to the group Managed Water Use. To define protected areas, the International Union for Conservation of Nature (IUCN) and United Nation Environment Programme (UNEP) database for protected areas was used. These bodies publish digital boundaries of Conserved Land Use classes (e.g. <http://www.protectedplanet.net/>).

3.2 Precipitation

WA+ uses gross precipitation as the primary input. Precipitation products such as the Tropical Rainfall Measurement Mission (TRMM), the Climate Prediction Center Morphing Technique (CMORPH) (Joyce et al., 2004), the Precipitation Estimation from Remotely Sensed Information using Artificial Neural Networks (PERSIANN) (Sorooshian et al., 2000), provide freely available global precipitation data with different spatial and temporal resolutions.

Rainfall data from the calibrated TRMM map was used for this accounting procedure. Cheema and Bastiaanssen (2012) calibrated TRMM rainfall for Indus Basin with two methods including (a) a regression analysis against rain gauges and (b) a Geographical Differential Analysis (GDA). Using Nash–Sutcliffe efficiency (NSE) and standard error of estimates (SEE) they concluded that calibration with the GDA method resulted in a closer correlation with rain gauge data than a simple regression equation. Both calibrations in general showed a reasonable accuracy however (NSE > 0.8). The quality of the GDA method is highly dependent on the distribution of rain gauges in the network. In the Indus Basin the majority of stations are located in the low altitude plains whereas most of the precipitation occurs in the mountainous un-gauged part of the basin. The GDA method is thus likely to underestimate rainfall in the northern mountains and highlands. For these reasons, and to overcome the issue of underestimation of the rainfall by the GDA method, a new map was produced which combines the result of the two calibrations. The resulting map is shown in Fig. 1a. The annual rainfall in the basin (using this method) was 415 mm yr^{-1} (i.e. a volume of 482 km^3) in 2007. Laghari et al. (2012) reported an average long term annual precipitation in the Indus Basin of

Basin-wide water accounting using remote sensing data

P. Karimi et al.

Title Page

Abstract

Introduction

Conclusions

References

Tables

Figures

◀

▶

◀

▶

Back

Close

Full Screen / Esc

Printer-friendly Version

Interactive Discussion



446 to 497 km³ based on two datasets (GWSP, 2008; Hijmans et al., 2005) and figures provided by various authors (Immerzeel et al., 2010; Karim and Veizer, 2002; Mitchell and Jones, 2005). The range compares well with our estimate especially seeing that 2007 was a wet year (PBS, 2008).

5 3.3 Evapotranspiration and biomass production

Various methods and algorithms to estimate actual evapotranspiration (ET) through satellite measurements have been developed over the past decades. Methods such as SEBAL (Bastiaanssen et al., 1998), SEBS (Su, 2002), TSEB (Norman et al., 2000), METRIC (Allen et al., 2007), Alexi (Anderson et al., 2007) and ETWatch (Wu et al., 2012), amongst others are used widely to estimate ET and are increasingly accepted (e.g. Kalma et al., 2008; Verstraeten et al., 2005). Products such as MOD 16 (<http://modis.gsfc.nasa.gov>) offer daily ET data at 1 km² resolution that can be downloaded by users for free.

For this accounting exercise, ET data of the Indus Basin for 2007 was produced using the new ETLook algorithm (Bastiaanssen et al., 2012). ETLook is a two-layer surface energy balance model that adopts microwave-based soil moisture data to solve the partitioning of net radiation into latent heat flux, sensible heat flux and soil heat flux. ETLook computes evaporation (E) and transpiration (T) separately using Leaf Area Index to partition total net radiation into canopy and soil components. ETLook also provides spatially distributed data for interception (I) and a special subroutine for open water evaporation. Figure 1c and d show the annual E and T values respectively, of the Indus Basin. The total ET of the basin in 2007 was 501 km³, of which T accounts for 229 km³ and, E and I for 272 km³. The data was compared against field measurements of lysimeters, Bowen ratio flux towers and water balance data in Pakistan (Bastiaanssen et al., 2012). The RMSE was 0.29 mm d⁻¹, R^2 was 0.76, and bias was 6.5%.

Basin-wide water accounting using remote sensing data

P. Karimi et al.

Title Page

Abstract

Introduction

Conclusions

References

Tables

Figures

◀

▶

◀

▶

Back

Close

Full Screen / Esc

Printer-friendly Version

Interactive Discussion



and changes in ground water levels (e.g. Ahmad et al., 2005). This unfortunately does not provide a reliable and reproducible data set either. Despite heavy utilization of groundwater in the Indus, direct measurements on groundwater change remain limited. The WA+ offers the possibility to estimate total bulk groundwater storage change through mass conservation of the water balance. This is only feasible if ET data is available, because ET is usually computed as the residual term in the water balance. Measured outflow is used to back calculate total groundwater storage change by closing the water balance. It appears that an amount of 29.8 km^3 was extracted from groundwater storage during 2007.

3.4.3 Glacier and snowstorages

Glacier and snow melt are major contributors to river flow. The glacier area in the Indus Basin is estimated at $22\,127 \text{ km}^2$ (Immerzeel et al., 2010). Bolch et al. (2012) estimated the annual specific mass balance of Himalayan-Karakoram glacier to be around -0.5 m per year during the last decade. Based on findings of Fowler and Archer (2006), the Karakoram glacier with an area of $18\,000 \text{ km}^2$ is believed to be stable. The change in glacier storage over an area of $4\,127 \text{ km}^2$ ($22\,127 - 18\,000$) will yield an annual streamflow of 2.1 km^3 ($4\,127 \times 0.5 \times 0.001 = 2.1$) (W. W. Immerzeel, personal communication, 2012). Information on glacier storage change in a specific year is scant. We therefore used an average annual estimate as representative for 2007 in this study.

4 WA+ sheets for the Indus Basin

4.1 Resource base sheet

The WA+ resource base sheet for 2007 is presented in Fig. 2. The net inflow is 523 km^3 of which 482 km^3 originates from precipitation. The remaining 41 km^3 is derived from fresh water storage. As described above, the major share of storage decline is ascribed

Basin-wide water accounting using remote sensing data

P. Karimi et al.

Title Page

Abstract

Introduction

Conclusions

References

Tables

Figures

◀

▶

◀

▶

Back

Close

Full Screen / Esc

Printer-friendly Version

Interactive Discussion



to groundwater extraction (29.8 km³) followed by 9.4 and 2.1 km³ loss of storage from surface reservoirs and glaciers respectively.

Inter basin transfer does certainly occur underground via the quaternary upper tertiary deposits. The amounts are however difficult to quantify and are assumed to be small in comparison to other water balance components. Due to the absence of documented estimates on groundwater outflow to the sea – or intrusion – exchanges with the Indian Ocean are ignored as well. All inter basin transfers are set at zero.

The net inflow is divided into “Landscape ET” (green water consumption – the direct ET from rainfall) and “Blue water” (water in streams, lakes, reservoirs, snow cover, glaciers and aquifers). The “landscape ET” accounts for 344 km³ (66 % of the net inflow and 71 % of total gross precipitation). This is a substantial water volume that can hardly be managed. The blue water is 180 km³, being 34 % of the net inflow.

The major water consuming land use category is the group MWU. The total water consumption by MWU accounts for 264 km³, slightly over 50 % of the net inflow. Of 264 km³ water consumption by MWU, 107 km³ (or 41 %) is directly from rainfall over the irrigated areas, urban areas, and reservoirs; thus part of landscape ET. The remaining incremental ET (157 km³) originates from utilized water flows.

The other components of the landscape ET include ET from CLU, ULU, and MLU. Within the “landscape ET” the group ULU takes up 178 km³ of water which makes it the second largest water consumer. These are the savanna, forests, deserts, natural lakes which all provide ecosystem services. The group MLU (essentially rainfed crops) consume 44 km³ and the group CLU uses only 15 km³. Table 2 shows the breakdown of ET by LULC classes within these groups.

Based on the Inter-provincial Water Apportion Accord 1991, an amount of 12.3 km³ of flow should be set aside annually to meet the environmental flow requirements to curb sea water intrusion in the Indus delta (Ram, 2010). This water volume, based on water rights formulation, is treated as reserve flow in WA+. The difference between the total blue water and the reserved flows (167 km³) is the available water of which 157 km³ is consumed by MWU as a result of water diversions and 1 km³ flows to sinks

Basin-wide water accounting using remote sensing data

P. Karimi et al.

Title Page

Abstract

Introduction

Conclusions

References

Tables

Figures



Back

Close

Full Screen / Esc

Printer-friendly Version

Interactive Discussion



(i.e. saline groundwater aquifers) and renders it unavailable for further use due to quality degradation. Utilizable flow, the difference of available water and utilized water, is estimated at 8 km^3 for 2007. Utilizable flow represents the amount that is available for further water resources development. But to establish the amount reliably would need a multi-year assessment. The notable point is that the Indus Basin has some surplus water leaving the basin while it is losing its precious ground water storage at a fast rate. With better storage and artificial recharge regulations, utilizable flow can be used to reduce storage depletion.

The total depleted water in the Indus Basin is 502 km^3 and it happens almost entirely through ET process (501 km^3). One km^3 of depleted water ends up in sinks and gets added to the polluted water storage (ΔS_p). An amount of 21.3 km^3 water flows into the Indian Ocean. This figure was derived from discharge measurements.

4.2 Consumptive use sheet

The WA+ consumptive use sheet (Fig. 3) divides the total ET into evaporation (E), transpiration (T) and interception (I) for each LULC (Table 2). The consumptive use sheet also expresses the benefits, and the WA+ user can insert a judgment value to estimate to what extent water is consumed beneficially. Figure 4 shows the WA+ consumptive use sheet for the Indus. For this example all the transpiration is assumed to be 100% beneficial except for transpiration from floating vegetation in reservoirs, waste lands and weeds. All the interception is non-beneficial and except for evaporation from natural lakes and industries (e.g. cooling towers, hydropower, etc.) all the evaporation is 100% non-beneficial. These proportions of beneficial and non-beneficial E and T can be defined/modified by users based on their judgment.

In terms of total volume, T comes second to E . This implies that bare soil E is the main process through which water is depleted. In the accounting year, 261, 229, and 12 km^3 were depleted by E , T and I , respectively. As a consequence, beneficial water consumption is limited to only 50% of total water consumption. It comprises of beneficial E (22.5 km^3) plus 228.5 km^3 beneficial T . Non-beneficial consumption accounts

Basin-wide water accounting using remote sensing data

P. Karimi et al.

Title Page

Abstract

Introduction

Conclusions

References

Tables

Figures



Back

Close

Full Screen / Esc

Printer-friendly Version

Interactive Discussion



for 251 km³, with non-beneficial *E* being the major contributor (238 km³). As demonstrated in Fig. 2c, this occurs mainly in the downstream areas of the Sindh province. The total agricultural water consumption is 297 km³, out of which 165 km³ occurs via *T* and 132 km³ through *E* and *I*. This is an unfavorable situation that requires corrective action. For typical situations in the irrigation systems of Pakistan, *T* is 2/3 of the total ET (Ahmad et al., 2002).

4.3 Productivity sheet

Biomass production by LULC class is an indication of profits in terms of food, feed and fiber (see Fig. 4). The total biomass production in the accounting year was 1015 million tons (Mt), which translates into an average production of 8.8 t ha⁻¹ yr⁻¹ when taking into account the gross basin area. Results show that MWU is the major contributor to biomass production (596.7 Mt and 21.4 t ha⁻¹). MWU is followed by ULU that produces 356 Mt of biomass in accounting year, equal to 5.8 t ha⁻¹. The remaining two classes MLU and CLU have minor shares in the total biomass production.

Water consumption indirectly results in sequestering a total of 584 Mt of CO₂ in the Indus Basin as a consequence of fresh biomass production. As the ecosystem of each LULC class has a certain maximum value of standing biomass, part of the total standing biomass will be decayed by natural death and competition among species. This decay is not included in the production sheet, because the sheet accounts for carbon assimilation only. The annually sequestered carbon varies with land use class. A large part of the sequestered carbon in biomass of crops is removed from the field after harvest, except when crop residuals are ploughed back. The carbon value of each land use class is expressed as a fraction of the annually produced biomass (not shown). The absorption of 390.8 Mt of carbon annually shows the important role of that ULU in carbon absorption and thus as an environmental services provider. The figure translates to 6.4 t ha⁻¹ which is higher than the average 5.1 t ha⁻¹ of CO₂ in the basin. MWU is the second major land use group in terms of carbon sequestration. It removes 160 Mt

Basin-wide water accounting using remote sensing data

P. Karimi et al.

Title Page

Abstract

Introduction

Conclusions

References

Tables

Figures

◀

▶

◀

▶

Back

Close

Full Screen / Esc

Printer-friendly Version

Interactive Discussion



of CO₂, equal to 5.7 tha⁻¹, from the atmosphere and creates soil organic matter. CLU contributes to 23 Mt of CO₂ sequestration followed by MLU with 10.3 Mt CO₂. Note that this is the gross sequestration and that net sequestration due to natural decay is not considered.

Land productivity was calculated for a hypothetical cereal reference crop with a harvest index of 0.35. Land productivity represents a mixture of crops and is therefore a better expression than crop yield. In the irrigated sector, the average annual land productivity is about 7.8 tha⁻¹yr⁻¹. This figure in most areas represents the harvest of two seasons. For a single crop it would be 3.9 tha⁻¹, a value that is realistic for the cereals. Land productivity for rainfed agriculture is estimated at 0.94 tha⁻¹. With technical assistance, this could be increased.

Water productivity (WP) is a fundamental indicator in performance assessment of river basins and it has immense food security implications (Molden, 2007). In the Indus Basin WP in terms of biomass production per hectare is close to 2 kgm⁻³. MWU has the highest biomass WP among all the land use groups (2.3 kgm⁻³). It is followed by 2.0, 1.1 and 1.1 kgm⁻³ for ULU, CLU, and MLU respectively. The average crop water productivity is calculated based on the estimated reference yields and annual ET. Results show crops WP in irrigated agriculture to be 0.77 kgm⁻³ which for the rainfed is 0.35 kgha⁻¹. This shows that WP in the basin is low compared to many other basins across the world (Cai et al., 2011). The higher performing areas within the Indus Basin have a WP value of 1.2 kgm⁻³ (Cai and Sharma, 2010). The world-wide average value for wheat is 0.98 kgm⁻³, rice is 0.98 kgm⁻³ and corn reaches 2.25 kgm⁻³ (W. G. M. Bastiaanssen and P. Steduto, personal communication, 2012). With 0.6 kgm⁻³ average WP, the Indus Basin is among the low performing basins in terms of productive use of water.

Basin-wide water accounting using remote sensing data

P. Karimi et al.

Title Page

Abstract

Introduction

Conclusions

References

Tables

Figures

◀

▶

◀

▶

Back

Close

Full Screen / Esc

Printer-friendly Version

Interactive Discussion



4.4 Withdrawal sheet

The WA+ withdrawal sheet provides information on total withdrawal (surface water diversions and groundwater abstractions). The withdrawn water from surface and groundwater systems is that which is consumed by crops, open water bodies, industries, domestic uses, etc. The non-consumed water returns to the hydrological system. The return flow is partitioned into surface water and groundwater. Withdrawal data cannot be derived from satellite measurements. Other sources, such as secondary statistics and hydrological model outputs, need to be consulted if available. For the Indus Basin, in addition to the remotely sensed data, FAO Aquastat database, canal water release information from the Line Agencies and Soil and Water Assessment Tool (SWAT) model results, were used to complete the WA+ withdrawal sheet.

The SWAT modeling results – after assimilating the remote sensing data – showed that an amount of 181 km³ of water is diverted for use in agriculture in 2007 (Cheema, 2012). Of this 68 km³ originates from groundwater while surface water contributes 113 km³. Of the 181 km³ gross withdrawal for irrigation, 152 km³ is consumed by ET and the remaining non-consumed water (30 km³) is recovered in the system. Aquastat estimates withdrawals for domestic and industrial uses as 1.8 and 12.2 km³ a year respectively; a combined withdrawal of 14 km³. Out of this an amount of 4.6 km³ is consumed by ET which leaves the majority to be non-consumed (9.4 km³). The total ET from the LULC class urban and industrial settlements is 8.7 km³ larger than the 4.6 km³ (see Table 2), but part of the ET is attributed to rainfall. The incremental ET from reservoir operation is 1 km³, which by itself is a large volume, but relatively small compared to the other MWU classes (0.5%). Figure 6 shows the WA+ withdrawal sheet for the Indus Basin. Gross withdrawals in the accounting year is estimated at 196 km³, out of which 118 km³ is diverted from surface water systems and the rest (78 km³) was pumped out from aquifers.

After correction for non-recoverable flow to sinks, the recoverable flow will be 37.8 km³. The total return flow is partitioned between surface water (SW) and

HESSD

9, 12921–12958, 2012

Basin-wide water accounting using remote sensing data

P. Karimi et al.

Title Page

Abstract

Introduction

Conclusions

References

Tables

Figures



Back

Close

Full Screen / Esc

Printer-friendly Version

Interactive Discussion



groundwater (GW) systems using a fraction derived from SWAT. The return flows are estimated to be 21.6 and 16.7 km³ for SW and GW respectively. There is also the direct interaction between SW and GW within MWU. Seepage from irrigation canals is responsible for 38 km³ flowing from SW to GW (Cheema, 2012). The flow from GW to SW is 20 km³ (Fig. 5). A mass balance of the bulk aquifer indicates that groundwater storage depletion in MWU alone is 43.3 km³. The feeding of aquifers from the other LULC classes that have no withdrawals is however not considered. Van Steenberg and Gohar (2005) estimated this amount to be 14 km³, leaving the ΔS_{gw} to be approximately 29.3 km³. The value for ΔS_{gw} found in the water resources sheet was 29.8 km³, a value being very similar.

5 WA+ performance indicators

The WA+ offers a range of standard indicators (see Table 3). Every sheet comes with its own indicators that are derived from information in the sheets (Karimi et al., 2012).

The WA+ resource base sheet indicators include a storage change fraction, a blue water fraction, an available water fraction, a basin closure fraction, and a reserved flow fraction. The blue water fraction (BWF) represents the portion of blue water in the net inflow. The storage change fraction (SCF) defines the portion of storage change in blue water. BWF is closely related to the run-off coefficient in a basin. However, it also includes storage change. A high BWF can be due to a high run-off coefficient or a high use of water from storage. The Indus Basin with a BWF of 0.34 falls in the category of basins with a high BWF. This is partly due to use of storage, revealed by the low negative SCF of -0.23. Available water fraction (AWF) indicates the proportion of the blue water that is actually available for withdrawals after corrections for reserved flows. The AWF of the Indus Basin is calculated at 0.93 which indicates that the basin's water commitments are not a constraining factor for allocations.

Basin Closure Fraction (BCF) describes the extent to which available water is utilized in a basin. While a BCF value of 1 indicates all available water is utilized, a BCF value

Basin-wide water accounting using remote sensing data

P. Karimi et al.

Title Page

Abstract

Introduction

Conclusions

References

Tables

Figures



Back

Close

Full Screen / Esc

Printer-friendly Version

Interactive Discussion



of higher than 1 implies that utilized water has surpassed the available water and is drawing from reserved flows. The Indus with a BCF of 0.95 falls among basins in which utilized water is reaching its maximum in terms of volume. This leaves a limited window for further increases in withdrawals.

Reserved flow fraction (RFF) defines whether or not surface water outflow is meeting the required reserved flow. A RFF of 0 to 1 means that reserved flows are met, whereas values more than 1 indicate that the system has not released enough water to satisfy demands. The RFF in the Indus Basin is estimated at 0.58 which suggests that outflows from the basin are almost two times bigger than reserved flows. However, most of these outflows (17.1 km³) take place during the wet season (Kharif); outflow during the dry season (Rabi) is only 4.2 km³. This echoes the need for additional storage facilities in the basin to maintain environmental flow throughout the year. A reservoir also facilitates the re-distribution of water throughout the year.

The WA+ consumptive use sheet has five indicators namely a transpiration fraction, a beneficial fraction, a managed fraction, an agricultural ET fraction, and an irrigated ET fraction. The transpiration fraction gives an indication of which part of the consumptive use is vaporized via plant leaves. For the Indus Basin the ratio is 0.46, meaning the majority of water consumption in the basin is through soil and water evaporation and interception of canopies and other wet surfaces; something that is unfavorable.

The managed fraction represents the portion of ET that is related to any human interventions (MLU, MWU), and can be used to help save water (Seckler, 1996). MWU includes both rainfed and irrigated systems, as well as industrial and domestic uses. The managed fraction for the Indus Basin in the accounting period is 0.61 which that human activities in the basin dictate consumption of water to a large extent. The agricultural ET fraction in the basin is 0.59 which shows that agricultural activities are intense water consumers. The reason is the extremely large extent of agriculturally related LULC area that covers almost 40% of the total area of the basin. The irrigated ET fraction for the basin is 0.85, which indicates that 85% of agricultural water consumption is through irrigated systems.

Basin-wide water accounting using remote sensing data

P. Karimi et al.

Title Page

Abstract

Introduction

Conclusions

References

Tables

Figures



Back

Close

Full Screen / Esc

Printer-friendly Version

Interactive Discussion



Basin-wide water accounting using remote sensing data

P. Karimi et al.

Title Page

Abstract

Introduction

Conclusions

References

Tables

Figures

◀

▶

◀

▶

Back

Close

Full Screen / Esc

Printer-friendly Version

Interactive Discussion



The productivity sheet indicators are meant to reflect the basin's performance in productive use of land and water resources. Land productivity in cropped areas in the Indus Basin is estimated at $5020 \text{ kg ha}^{-1} \text{ yr}^{-1}$ (rainfed: 938 kg ha^{-1} ; irrigated: 7768 kg ha^{-1}). Land productivity of pastures is essential for grazing. Pasture productivity can also be used to value pastures in terms of economic benefit. Land productivity of pastures is about $0.18 \text{ t ha}^{-1} \text{ yr}^{-1}$, which is a relatively low figure due to desert conditions. Food irrigation dependency deals with the level to which a basin relies on irrigated agriculture for food production. The ratio is 0.9 for the Indus Basin indicating that food security is highly dependent on continued irrigated agriculture.

Basin level efficiency is an indication of the efficacy of irrigation from a basin-wide approach. It has more meaning than traditional farm and irrigation scheme level efficiencies. Results show the basin enjoys a relatively high effective efficiency of 0.84 at basin level (Keller and Keller, 1999) despite its low irrigation application efficiency of 0.35 to 0.40 (Qureshi, 2011). Hence, in general, the system is efficient in capturing and reusing water losses from farms and conveyance canals through the natural geographic setting. Thus in spite of common belief that have reduction of losses at the center of proposed solutions, it is herewith demonstrated that these losses are largely captured and reused by downstream users. The recycling factor for the basin (0.2) indicates that 20% of the gross water withdrawals are recovered into the hydrological system and reused through surface and groundwater systems.

6 Alternative solutions

Water accounting results demonstrate that there is limited scope for more water withdrawals in the basin and almost no opportunity to allocate more water for agriculture. In the remarks column of Table 3 a number of problems that need more attention are listed. It should be noted that this paper is not dealing with solutions for the Indus. The intention is merely to demonstrate the contribution of WA+ for appraising basin scale water management options. The main problems in a nutshell are:

in shallow water table areas by means of installation of sub-surface drainage systems (Smedema, 2000).

The need to reduce soil evaporation becomes clear from the following analysis: in nearly 8.8 million ha of irrigated lands in the basin E accounts for more than 40 % of ET. Limiting E to 40 % of the total ET would result in a net saving of 7.7 km^3 of water. Water saving would increase significantly to 13.3 km^3 if $E/ET < 0.36$ is introduced in irrigated areas.

If the increasing food demands are to be met, then agricultural production needs to be improved. Since land productivity is genuinely low, it is imperative to investigate options to improve yields. Crop yield is a function of biomass production and harvest index. The biomass production can be improved by better fertilization and the selection of good quality seeds. The uniformity, adequacy and reliability of irrigation systems contribute to the production of a healthy biomass (Murray-Rust et al., 1994). Uniform water distribution by means of drip systems and land leveling will ensure a low spatial variability of biomass. Adequate irrigation prevents moisture stress and reliable surface water supply will ensure that farmers invest more time and resources in their crop. With these measures a 5 % increase in biomass production is plausible. The harvest index varies mainly with crop variety and the soil moisture situation during flowering and panicle stage. An adequate supply during this critical period can increase the harvest index by 5 to 10 % (Doorenbos and Pruitt, 1977). A consequence of more biomass production is that T will increase. Steduto et al. (2009) established an empirical relationship between biomass production and T which forms the basis of the AquaCrop model. Every increase of 1 mm in T – normalized against reference ET_0 – will increase biomass production by 13 kg ha^{-1} . So biomass production improvement will increase ET, unless E is reduced concomitantly. Thus ET reduction can be achieved only if the reduction of E exceeds the increase of T .

It is not new to conclude that the crop water productivity in the Indus Basin is low (Bastiaanssen et al., 2003; Cai and Sharma, 2010). In a system like the Indus simple and inexpensive techniques such as improved irrigation scheduling and sufficient

Basin-wide water accounting using remote sensing data

P. Karimi et al.

Title Page

Abstract

Introduction

Conclusions

References

Tables

Figures



Back

Close

Full Screen / Esc

Printer-friendly Version

Interactive Discussion



drainage along with replacing traditional irrigation method with micro-irrigation systems, will help not only to increase yields but also to cut back on evaporative losses and increase uniformity, reliability and adequacy (Kahlow et al., 2007). By reducing E , increasing T and increasing yield, water productivity is expected to increase. Table 4 demonstrates the real water savings and the adjusted WA+ indicators under 3 scenarios, which are built around existing options to achieve water saving and better food security targets.

Alternative A is based on some mixed interventions, however it will not bring sufficient real water savings. Scenario B is based on reducing soil evaporation losses by mulching, drainage and micro-irrigation (drip and micro-sprinkler). Note that micro-irrigation will contribute to crop production and crop water productivity (Soman, 2012). Sub-surface irrigation is rapidly being adopted in India, and the same is feasible in Pakistan. Hence farmers have a better future with improved livelihoods if scenario B is adopted by policy makers. Figure 7 shows the WA+ resource base sheet after implementing scenario B. Alternative C is based on a land retirement plan. This is likely going to happen if other interventions are not timely implemented.

Policy makers have to make a choice between these options. Proposed actions are feasible, provided that large scale programs are started to advocate land leveling, micro-irrigation, canal water operations, on-farm water management, subsurface drainage systems, salinity control, maintenance of irrigation and drainage canals, etc. Simultaneously, crop yield improvement through breeding should be revitalized and selection of foreign varieties should be encouraged. The role of fertilizer advice from supplier industries to boost biomass production of crops should be encouraged. Such interventions may need a significant micro-credit and loan program, as many smallholders need to invest in order to end up with higher achievements. WA+ demonstrates that with these interventions, the future of the Indus Basin will be more progressive.

It is important to note that the above analyses are only based on results of water accounting in 1 yr (2007) and are merely to demonstrate how the WA+ functions in

Basin-wide water accounting using remote sensing data

P. Karimi et al.

Title Page

Abstract

Introduction

Conclusions

References

Tables

Figures

◀

▶

◀

▶

Back

Close

Full Screen / Esc

Printer-friendly Version

Interactive Discussion



scenario development and assessment. Therefore results must be treated with caution and future research through multiple year analysis is required to validate the outcomes.

7 Summary and conclusions

Future sustainability of the Indus Basin is threatened by a host of issues, such as water scarcity, rapid population growth, groundwater over exploitation, water logging, and low productivity of land and water resources. A clear understating of current water flows is the cornerstone for informed water management strategies for the future. However, data availability and a standard way of presenting data are two main obstacles in providing comprehensive, yet easy to comprehend, information on water management.

In this study we used the Indus Basin as an example to demonstrate how the WA+ framework can be implemented to provide much-needed explicit information on the water resources situation, uses, and productivity, in a systematic way by using minimum ground measured data and how the accounting results can be used to identify weaknesses, strengths, and opportunities.

The results show that the Indus Basin is nearly a closed basin in which more than 95 % of the available water is used. Almost all depleted water can be ascribed to ET. The Managed Water Use group, chiefly dominated by irrigated agriculture, accounts for 52 % of ET. It is followed by the Utilized Land Use (36 %), Modified Land Use (9 %) and Conserved Land Use (3 %). Half of the water consumption is through processes that produce very little or no benefits, i.e. non-beneficial use. The majority of these non-beneficial uses is through human intended water consumption, particularly through irrigated agriculture in the form of excessive soil evaporation.

On the supply side, precipitation falls short of meeting the water demand. This puts pressure on the water storage and leads to significant reduction in storage, especially groundwater storage (29.8 km³ in 2007). Such a fast decline in GW storage has major implications for the sustainability of the basin considering the crucial role that GW plays in the basin's food security.

Basin-wide water accounting using remote sensing data

P. Karimi et al.

Title Page

Abstract

Introduction

Conclusions

References

Tables

Figures



Back

Close

Full Screen / Esc

Printer-friendly Version

Interactive Discussion



Basin-wide water accounting using remote sensing data

P. Karimi et al.

Title Page

Abstract

Introduction

Conclusions

References

Tables

Figures

◀

▶

◀

▶

Back

Close

Full Screen / Esc

Printer-friendly Version

Interactive Discussion



While agriculture accounts for 59 % of total water consumption it has a considerably low productivity especially in terms of water use. Therefore, to improve the situation and reach sustainability in the water-food nexus, water and land productivity has to be improved. This will in turn result in increased production with reduced water consumption. The main opportunity for reducing water consumption is through decreasing wasteful soil evaporation in agricultural areas, particularly in irrigated land. The results show – based on a single year analysis – that an amount of 37.8 km³ can be saved, if non-beneficial E on rainfed land is reduced by 15 % and on irrigated land by 35 %, while increasing land productivity and crop production. Increasing land productivity will automatically contribute to increasing WP. This is attainable only if on-farm water management and adequate drainage techniques are rapidly introduced, fertilizer programs are launched, micro-credits are readily provided, and the agronomic improvements are realized. Policy makers and donor agencies should work out plans in that direction.

Acknowledgements. Funds for this research were provided through the Capacity Building Program of the International Water Management Institute (IWMI) through the CGIAR Research Program on Water Land and Ecosystems. The authors are thankful to Vladimir Smakhtin and Robyn Johnston for their comments and contribution in improving this paper.

References

- Ahmad, M.-D., Bastiaanssen, W. G. M., and Feddes, R. A.: Sustainable use of groundwater for irrigation: a numerical analysis of the subsoil water fluxes, *Irrig. Drain.*, 51, 227–241, 2002.
- Ahmad, M.-D., Bastiaanssen, W. G. M., and Feddes, R. A.: A new technique to estimate net groundwater use across large irrigated areas by combining remote sensing and water balance approaches, *Rechna Doab, Pakistan, Hydrogeol. J.*, 13, 653–664, 2005.
- Allen, R. G., Tasumi, M., and Trezza, R.: Satellite-based energy balance for mapping evapotranspiration with internalized calibration (METRIC) – model, *J. Irrig. Drain. E.-ASCE*, 133, 380–394, 2007.

Basin-wide water accounting using remote sensing data

P. Karimi et al.

Title Page

Abstract

Introduction

Conclusions

References

Tables

Figures

◀

▶

◀

▶

Back

Close

Full Screen / Esc

Printer-friendly Version

Interactive Discussion



- Anderson, M. C., Norman, J. M., Mecikalski, J. R., Otkin, J. A., and Kustas, W. P.: A climatological study of evapotranspiration and moisture stress across the continental United States based on thermal remote sensing: 1. Model formulation, *J. Geophys. Res.*, 112, D10117, doi:10.1029/2006JD007506, 2007.
- 5 Bartholomé, E. and Belward, A. S.: GLC2000: a new approach to global land cover mapping from Earth observation data, *Int. J. Remote Sens.*, 26, 1959–1977, 2005.
- Bastiaanssen, W. G. M., Menenti, M., Feddes, R. A., and Holtslag, A. A. M.: A remote sensing surface energy balance algorithm for land (SEBAL), 1. Formulation, *J. Hydrol.*, 212–213, 198–212, 1998.
- 10 Bastiaanssen, W. G. M., Ahmad, M.-D., Tahir, Z., Kijne, J. W., Barker, R., and Molden, D.: Upscaling Water Productivity in Agriculture: Limits and Opportunities for Improvement, edited by: Kijne, J. W., Barker, R., and Molden, D., CABI, Wallingford, 2003.
- Bastiaanssen, W. G. M., Cheema, M. J. M., Immerzeel, W. W., Miltenburg, I., and Pelgrum, H.: The surface energy balance and actual evapotranspiration of the transboundary Indus Basin estimated from satellite measurements and the ETLook model, *Water Resour. Res.*, doi:10.1029/2011WR010482, in press, 2012.
- 15 Birkett, C. M. and Beckley, B.: Investigating the performance of the Jason-2/OSTM radar altimeter over lakes and reservoirs, *Mar. Geod.*, 33, 204–238, 2010.
- Bolch, T., Kulkarni, A., Kääb, A., Huggel, C., Paul, F., Cogley, J. G., Frey, H., Kargel, J. S., Fujita, K., Scheel, M., Bajracharya, S., and Stoffel, M.: The state and fate of Himalayan glaciers, *Science*, 336, 310–314, 2012.
- 20 Bontemps, S., Defourny, P., and Van Bogaert, E.: GLOBCOVER 2009 products description and validation report, ESA and UCLouvain, Paris, France, 2010.
- Cai, X. and Sharma, B. R.: Integrating remote sensing, census and weather data for an assessment of rice yield, water consumption and water productivity in the Indo-Gangetic river basin, *Agr. Water Manage.*, 97, 309–316, 2010.
- 25 Cai, X., Molden, D., Mainuddin, M., Sharma, B., Ahmad, M.-D., and Karimi, P.: Producing more food with less water in a changing world: assessment of water productivity in 10 major river basins, *Water Int.*, 36, 42–62, 2011.
- 30 Cheema, M. J. M.: Understanding water resources conditions in data scarce river basins using intelligent pixel information, case: transboundary Indus Basin, PhD thesis, TU Delft, 2012.

Basin-wide water accounting using remote sensing data

P. Karimi et al.

Title Page

Abstract

Introduction

Conclusions

References

Tables

Figures

◀

▶

◀

▶

Back

Close

Full Screen / Esc

Printer-friendly Version

Interactive Discussion



Cheema, M. J. M. and Bastiaanssen, W. G. M.: Land use and land cover classification in the irrigated Indus Basin using growth phenology information from satellite data to support water management analysis, *Agr. Water Manage.*, 97, 1541–1552, 2010.

Cheema, M. J. M. and Bastiaanssen, W. G. M.: Local calibration of remotely sensed rainfall from the TRMM satellite for different periods and spatial scales in the Indus Basin, *Int. J. Remote Sens.*, 33, 2603–2627, 2012.

Doorenbos, J. and Pruitt, W. O.: *Crop water requirements*, Irrigation and Drainage Paper No. 24, FAO, Rome, Italy, 1977.

Fowler, H. J. and Archer, D. R.: Conflicting signals of climatic change in the upper Indus Basin, *J. Climate*, 19, 4276–4293, 2006.

Frappart, F., Papa, F., Güntner, A., Werth, S., Santos da Silva, J., Tomasella, J., Seyler, F., Prigent, C., Rossow, W. B., Calmant, S., and Bonnet, M.-P.: Satellite-based estimates of groundwater storage variations in large drainage basins with extensive floodplains, *Remote Sens. Environ.*, 115, 1588–1594, 2011.

Friedl, M. A., Sulla-Menashe, D., Tan, B., Schneider, A., Ramankutty, N., Sibley, A., and Huang, X.: MODIS Collection 5 global land cover: algorithm refinements and characterization of new datasets, *Remote Sens. Environ.*, 114, 168–182, 2010.

Godfrey, J. M. and Chalmers, K.: *Water accounting: international approaches to policy and decision-making*, Edward Elgar Publishing, Cheltenham, UK, 2012.

GWSP: GlobalWater System Project DigitalWater Atlas data, available at: <http://atlas.gwsp.org/> (last access: March 2012), 2008.

Habib, Z.: *Resource conservation and civil society: water and food security in Pakistan*, in: *Water for Food and Rural Development: Approaches and Initiatives in South Asia*, edited by: Molinga, P., Sage Publication, New Delhi, India, 182–196, 2000.

Henry, C. M., Allen, D. M., and Huang, J.: Groundwater storage variability and annual recharge using well-hydrograph and GRACE satellite data, *Hydrogeol. J.*, 19, 741–755, 2011.

Hijmans, R. J., Cameron, S. E., Parra, J. L., Jones, P. G., and Jarvis, A.: Very high resolution interpolated climate surfaces for global land areas, *Int. J. Climatol.*, 25, 1965–1978, 2005.

Immerzeel, W. W., van Beek, L. P. H., and Bierkens, M. F. P.: Climate change will affect the Asian water towers, *Science*, 328, 1382–1385, 2010.

Joyce, R. J., Janowiak, J. E., Arkin, P. A., and Xie, P.: CMORPH?: a method that produces global precipitation estimates from passive microwave and infrared data at high spatial and temporal resolution, *J. Hydrometeorol.*, 5, 487–503, 2004.

Basin-wide water accounting using remote sensing data

P. Karimi et al.

Title Page

Abstract

Introduction

Conclusions

References

Tables

Figures

◀

▶

◀

▶

Back

Close

Full Screen / Esc

Printer-friendly Version

Interactive Discussion



Kahlowan, M. A., Raoof, A., Zubair, M., and Kemper, W. D.: Water use efficiency and economic feasibility of growing rice and wheat with sprinkler irrigation in the Indus Basin of Pakistan, *Agr. Water Manage.*, 87, 292–298, 2007.

Kalma, J. D., McVicar, T. R., and McCabe, M. F.: Estimating land surface evaporation: a review of methods using remotely sensed surface temperature data, *Surv. Geophys.*, 29, 421–469, 2008.

Karim, A. and Veizer, J.: Water balance of the Indus River Basin and moisture source in the Karakoram and Western Himalayas: implications from hydrogen and oxygen isotopes in river water, *J. Geophys. Res.*, 107, D184362, doi:10.1029/2000JD000253, 2002.

Karimi, P., Bastiaanssen, W. G. M., and Molden, D.: Water Accounting Plus (WA+) – a water accounting procedure for complex river basins based on satellite measurements, *Hydrol. Earth Syst. Sci. Discuss.*, 9, 12879–12919, doi:10.5194/hessd-9-12879-2012, 2012a.

Karimi, P., Molden, D., Bastiaanssen, W. G. M., and Cai, X.: Water accounting to assess use and productivity of water: evolution of a concept and new frontiers, in: *Water Accounting: International Approaches to Policy and Decision-Making*, edited by: Godfrey, J. M. and Chalmers, K., Edward Elgar Publishing, Cheltenham, UK, 76–88, 2012b.

Laghari, A. N., Vanham, D., and Rauch, W.: The Indus basin in the framework of current and future water resources management, *Hydrol. Earth Syst. Sci.*, 16, 1063–1083, doi:10.5194/hess-16-1063-2012, 2012.

Mitchell, T. D. and Jones, P. D.: An improved method of constructing a database of monthly climate observations and associated high-resolution grids, *Int. J. Climatol.*, 25, 693–712, 2005.

Molden, D.: *Water for Food, Water for Life: a Comprehensive Assessment of Water Management in Agriculture*, Earthscan, London, 2007.

Murray-Rust, D. H., Gulati, O. T., Sakthivadivel, R., Prajapati, V. B., and Shukla, P. L.: Improving irrigation performance through the use of management information systems: the case of Mahi Kadana, Gujarat, India, *International Water Management Institute*, Colombo, Sri Lanka, 1994.

Norman, J. M., Kustas, W. P., Prueger, J. H., and Diak, G. R.: Surface flux estimation using radiometric temperature: a dual-temperature-difference method to minimize measurement errors, *Water Resour. Res.*, 36, 2263, doi:10.1029/2000WR900033, 2000.

PBS: Rainfall at Selected Stations, available at: http://www.pbs.gov.pk/sites/default/files/agriculture_statistics/rainfall_at_Selected_Stations.pdf (last access: 12 September 2012), 2008.

Prathapar, S. A. and Qureshi, A. S.: Mechanically reclaiming abandoned saline soils: a numerical evaluation, International Water Management Institute, Colombo, Sri Lanka, 1999.

Qureshi, A. S.: Water management in the Indus Basin in Pakistan: challenges and opportunities, *Mt. Res. Dev.*, 31, 252–260, 2011.

Ram, N.: An analysis of rural poverty trends in Sindh province of Pakistan, *Aust. J. Basic Appl. Sci.*, 4, 1403–1409, 2010.

Seckler, D.: The new era of water resources management: From “dry” to “wet” water savings, International Water Management Institute, Colombo, Sri Lanka, 1996.

Siebert, S., Burke, J., Faures, J. M., Frenken, K., Hoogeveen, J., Döll, P., and Portmann, F. T.: Groundwater use for irrigation – a global inventory, *Hydrol. Earth Syst. Sci.*, 14, 1863–1880, doi:10.5194/hess-14-1863-2010, 2010.

Smedema, L.: Irrigation-induced river salinization: five major irrigated basins in the arid zone, International Water Management Institute, Colombo, Sri Lanka, 2000.

Soman, P.: Drip irrigation and fertigation technology for rice cultivation, in: Asian Irrigation Forum 2012, Manila, Philippines, 2012.

Sorooshian, S., Hsu, K.-L., Gao, X., Gupta, H. V., Imam, B., and Braithwaite, D.: Evaluation of PERSIANN system satellite-based estimates of tropical rainfall, *B. Am. Meteorol. Soc.*, 81, 2035–2046, 2000.

Steduto, P., Hsiao, T. C., Raes, D., and Fereres, E.: AquaCrop – the FAO crop model to simulate yield response to water: I. Concepts and underlying principles, *Agron. J.*, 101, 426–437, doi:10.2134/agronj2008.0139s, 2009.

Su, Z.: The Surface Energy Balance System (SEBS) for estimation of turbulent heat fluxes, *Hydrol. Earth Syst. Sci.*, 6, 85–100, doi:10.5194/hess-6-85-2002, 2002.

Tang, Q., Gao, H., Yeh, P., Oki, T., Su, F., and Lettenmaier, D. P.: Dynamics of terrestrial water storage change from satellite and surface observations and modeling, *J. Hydrometeorol.*, 11, 156–170, 2010.

Thenkabail, P. S., Schull, M., and Tural, H.: Ganges and Indus River Basin land use/land cover (LULC) and irrigated area mapping using continuous streams of MODIS data, *Remote Sens. Environ.*, 95, 317–341, 2005.

UN: System of Environmental Economic Accounting for Water, Geneva, 2007.

HESSD

9, 12921–12958, 2012

Basin-wide water accounting using remote sensing data

P. Karimi et al.

Title Page

Abstract

Introduction

Conclusions

References

Tables

Figures

◀

▶

◀

▶

Back

Close

Full Screen / Esc

Printer-friendly Version

Interactive Discussion



Basin-wide water accounting using remote sensing data

P. Karimi et al.

Title Page

Abstract

Introduction

Conclusions

References

Tables

Figures

◀

▶

◀

▶

Back

Close

Full Screen / Esc

Printer-friendly Version

Interactive Discussion



Van Steenberg, F. and Gohar, S.: Ground water development and Management, Background paper 12, World Bank, Washington, DC, 2005.

Verstraeten, W. W., Veroustraete, F., and Feyen, J.: Estimating evapotranspiration of European forests from NOAA-imagery at satellite overpass time: towards an operational processing chain for integrated optical and thermal sensor data products, *Remote Sens. Environ.*, 96, 256–276, 2005.

Wada, Y., van Beek, L. P. H., van Kempen, C. M., Reckman, J. W. T. M., Vasak, S., and Bierkens, M. F. P.: Global depletion of groundwater resources, *Geophys. Res. Lett.*, 37, L20402, doi:10.1029/2010GL044571, 2010.

Wang, Z., Liu, Z., Zhang, Z., and Liu, X.: Subsurface drip irrigation scheduling for cucumber (*Cucumis sativus* L.) grown in solar greenhouse based on 20 cm standard pan evaporation in Northeast China, *Sci. Hortic.-Amsterdam*, 123, 51–57, 2009.

Wu, B., Yan, N., Xiong, J., Bastiaanssen, W. G. M., Zhu, W., and Stein, A.: Validation of ET-Watch using field measurements at diverse landscapes: a case study in Hai Basin of China, *J. Hydrol.*, 436–437, 67–80, 2012.

Zhang, G., Xie, H., Duan, S., Tian, M., and Yi, D.: Water level variation of Lake Qinghai from satellite and in situ measurements under climate change, *J. Appl. Remote Sens.*, 5, 053532, doi:10.1117/1.3601363, 2011.

Zhang, X., Pei, D., and Hu, C.: Conserving groundwater for irrigation in the North China Plain, *Irrig. Sci.*, 21, 159–166, 2003.

Basin-wide water accounting using remote sensing data

P. Karimi et al.

Table 1. Change in surface storage in the major reservoirs of Indus during 2007.

| Reservoir | Reservoir capacity (km ³) | Reservoir area (10 ⁹ m ²) | Water level change (m) | Change in surface storage (km ³) |
|-----------|---------------------------------------|--|------------------------|--|
| Tarbela | 13.9 | 0.26 | −10.3 | −2.67 |
| Mangla | 7.3 | 0.25 | −10.6 | −2.65 |
| Chashma | 0.88 | 0.006 | +3.9 | +0.02 |
| Bhakra | 9.6 | 0.17 | −6.4 | −1.07 |
| Pong | 8.6 | 0.24 | −12.8 | −3.06 |
| Total | 40.28 | 0.92 | | −9.4 |

[Title Page](#)
[Abstract](#)
[Introduction](#)
[Conclusions](#)
[References](#)
[Tables](#)
[Figures](#)
[◀](#)
[▶](#)
[◀](#)
[▶](#)
[Back](#)
[Close](#)
[Full Screen / Esc](#)
[Printer-friendly Version](#)
[Interactive Discussion](#)

Basin-wide water accounting using remote sensing data

P. Karimi et al.

Title Page

Abstract

Introduction

Conclusions

References

Tables

Figures

◀

▶

◀

▶

Back

Close

Full Screen / Esc

Printer-friendly Version

Interactive Discussion



Table 2. WA+ indicators for the Indus Basin based on the situation in 2007.

| Land use class | Land use group | E (mcm yr^{-1})* | T (mcm yr^{-1}) | ET (mcm yr^{-1}) |
|---|----------------|----------------------------------|---------------------------------|--------------------------------|
| Snow and ice permanent | CLU | 4374 | 157 | 4533 |
| Conserved areas | CLU | 6773 | 3092 | 10 117 |
| Snow and ice temporary | ULU | 7193 | 927 | 8127 |
| Bare soil | ULU | 7992 | 57 | 8053 |
| Very sparse vegetation | ULU | 2967 | 94 | 3073 |
| Pastures deciduous | ULU | 10 693 | 368 | 11 080 |
| Pastures evergreen lowland | ULU | 6469 | 874 | 7394 |
| Pastures deciduous alpine | ULU | 8093 | 234 | 8359 |
| Savanna evergreen open | ULU | 6606 | 1984 | 8696 |
| Savanna evergreen closed | ULU | 5336 | 7373 | 13 130 |
| Savanna deciduous | ULU | 23 199 | 2829 | 26 291 |
| Forests evergreen needleleaf | ULU | 8322 | 18 305 | 28 932 |
| Forests evergreen broadleaf | ULU | 1064 | 3682 | 5062 |
| Forests deciduous alpine | ULU | 6793 | 5550 | 13 007 |
| Forests/cropland alpine | ULU | 5104 | 15 457 | 21 955 |
| Natural lakes, rivers | ULU | 15 000 | 0 | 15 088 |
| Rainfed crops wheat/grams | MLU | 2591 | 857 | 3498 |
| Rainfed crops mixed cotton, wheat rotation/fodder | MLU | 4563 | 2541 | 7189 |
| Rainfed crops general | MLU | 16 976 | 3382 | 20 576 |
| Rainfed crops and woods | MLU | 8383 | 3702 | 12 361 |
| Irrigated mixed cotton, wheat rotation/orchards | MWU | 14 206 | 31 781 | 46 754 |
| Irrigated mixed cotton, wheat rotation/sugarcane | MWU | 16 619 | 23 889 | 41 183 |
| Irrigated rice, wheat rotation | MWU | 36 366 | 67 489 | 106 649 |
| Irrigated mixed rice, wheat rotation/cotton | MWU | 8452 | 12 098 | 20 776 |
| Irrigated wheat, fodder rotation | MWU | 7913 | 10 851 | 19 063 |
| Irrigated rice, fodder rotation | MWU | 9286 | 8054 | 17 420 |
| Irrigated mixed rice, wheat rotation/sugarcane | MWU | 656 | 1105 | 1779 |
| Urban and industrial settlements | MWU | 6534 | 2013 | 8744 |
| Reservoirs | MWU | 1900 | 0 | 1914 |

* $\text{mcm} = \text{million m}^3$

Basin-wide water accounting using remote sensing data

P. Karimi et al.

Title Page

Abstract

Introduction

Conclusions

References

Tables

Figures

◀

▶

◀

▶

Back

Close

Full Screen / Esc

Printer-friendly Version

Interactive Discussion



Table 3. Water consumption by LULC class in the Indus Basin in 2007.

| Indicators | Value | Unit | Remarks |
|---|-------|--------------------------------------|--|
| Resource base sheet | | | |
| Blue water fraction | 0.34 | | Plenty of renewable water resources |
| Storage change fraction | −0.23 | – | Highly unsustainable situation |
| Available water fraction | 0.93 | – | Low amount assigned to reserved flow |
| Basin closure fraction | 0.95 | – | Almost closed to new development |
| Reserved flow fraction | 0.58 | – | Downstream requirements are met |
| Consumptive use sheet | | | |
| <i>T</i> fraction | 0.46 | – | Low canopy water consumption |
| Beneficial fraction | 0.50 | – | Low benefits from water consumption |
| Managed fraction | 0.61 | – | Many ET processes can be regulated |
| Agri. ET fraction | 0.59 | – | Agriculture is a major water consumer |
| Irr. ET fraction | 0.85 | – | Irrigation uses most agricultural water |
| Productivity sheet | | | |
| Land productivity _{crops} | 5020 | kg ha ^{−1} yr ^{−1} | Very low crop yield |
| Land productivity _{pastures} | 177.4 | kg ha ^{−1} yr ^{−1} | Extremely low grazing opportunities |
| Water productivity _{crops rainfed} | 0.35 | kg m ^{−3} | Rainfed crops not efficient with water |
| Water productivity _{crops irrigated} | 0.77 | kg m ^{−3} | Irrigated crops not efficient with water |
| Food Irr. Dependency | 0.90 | – | Food security relies on irrigation |
| Withdrawals sheet | | | |
| GW withdrawal fraction | 0.40 | – | Reliance on groundwater is significant |
| CE (Classical efficiency), basin level | 0.84 | – | Basin as a whole is an efficient system |
| Recycling factor | 0.20 | – | Recycling situation is normal |

Table 4. Impact of alternative solutions on WA+ indicators aiming at zero-overexploitation and increase food security.

| Scenario | Action | Real water saving (km ³ yr ⁻¹) | WA+ indicators |
|----------------------|--|---|---|
| A Mixed actions | – Reduce <i>E</i> rainfed land by 5 % | 12.6 | Storage change fr.: –0.17 Reserved flow fr.: 0.73 <i>T</i> fr.: 0.48 Beneficial fr.: 0.53 Land productivity _{irri} : 8560 Land productivity _{rainfed} : 1030 Water productivity _{irri} : 0.90 GW withdrawal fr.: 0.41 |
| | – Reduce <i>E</i> irrigated land by 15 % | | |
| | – Reduce irrigated area by 0 % | | |
| | – Biomass production increase 5 % | | |
| | – Harvest index increase 5 % | | |
| | – Reduce utilizable flow by 50 % | | |
| B Reduce <i>E</i> | – Reduce <i>E</i> rainfed land by 15 % | 37.8 | Storage change fr.: –0.02 Reserved flow fr.: 0.85 <i>T</i> fr.: 0.50 Beneficial fr.: 0.55 Land productivity _{irri} : 9300 Land productivity _{rainfed} : 1130 Water productivity _{irri} : 1.09 GW withdrawal fr.: 0.32 |
| | – Reduce <i>E</i> irrigated land by 35 % | | |
| | – Reduce irrigated area by 0 % | | |
| | – Biomass production increase 5 % | | |
| | – Harvest index increase 10 % | | |
| | – Reduce utilizable flow by 75 % | | |
| C Modify area | – Reduce <i>E</i> rainfed land by 5 % | 39.4 | Storage change fr.: –0.01 Reserved flow fr.: 0.85 <i>T</i> fr.: 0.45 Beneficial fr.: 0.50 Land productivity _{irri} : 9300 Land productivity _{rainfed} : 1130 Water productivity _{irri} : 0.93 GW withdrawal fr.: 0.30 |
| | – Reduce <i>E</i> irrigated land by 15 % | | |
| | – Reduce irrigated area by 15 % | | |
| | – Biomass production increase 5 % | | |
| | – Harvest index increase 10 % | | |
| | – Reduce non-utilizable flow by 75 % | | |

Basin-wide water accounting using remote sensing data

P. Karimi et al.

Title Page

Abstract

Introduction

Conclusions

References

Tables

Figures

◀

▶

◀

▶

Back

Close

Full Screen / Esc

Printer-friendly Version

Interactive Discussion



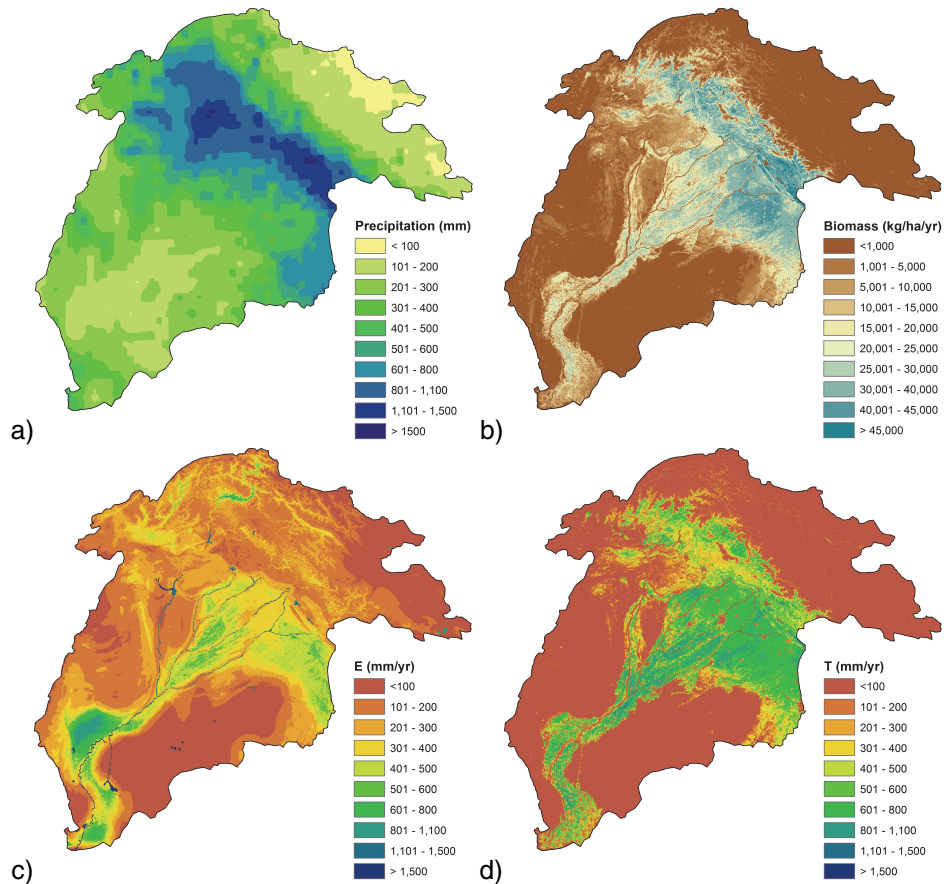

Fig. 1. (a) Precipitation (based on data from Cheema and Bastiaanssen, 2012) **(b)** biomass **(c)** evaporation **(d)** transpiration (based on data from Bastiaanssen et al., 2012) in the Indus Basin.

Basin-wide water accounting using remote sensing data

P. Karimi et al.

Title Page

Abstract Introduction

Conclusions References

Tables Figures

◀ ▶

◀ ▶

Back Close

Full Screen / Esc

Printer-friendly Version

Interactive Discussion



Basin-wide water accounting using remote sensing data

P. Karimi et al.

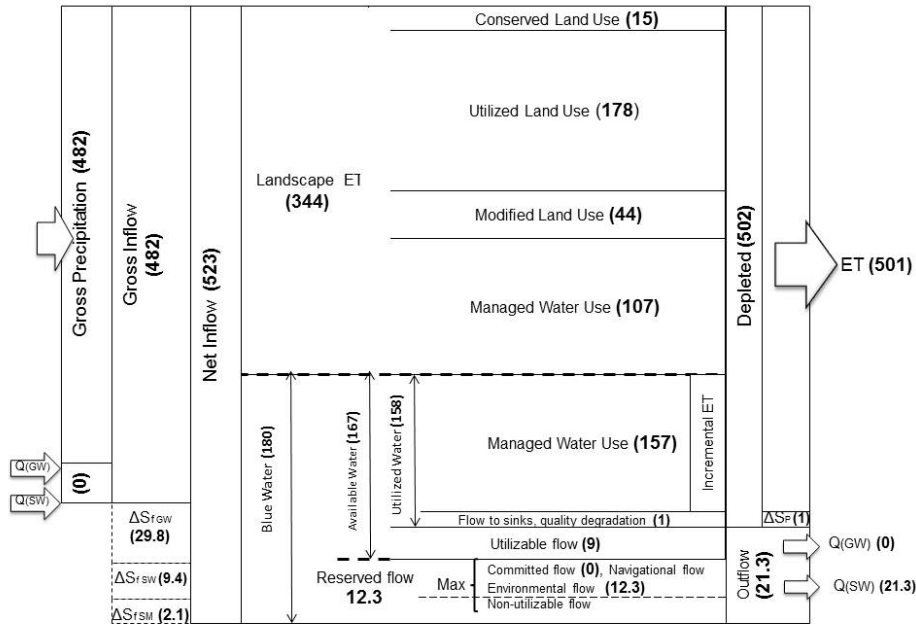

Fig. 2. WA+ resource base sheet for the Indus Basin during 2007. All components are in km³.

Title Page

Abstract

Introduction

Conclusions

References

Tables

Figures

◀

▶

◀

▶

Back

Close

Full Screen / Esc

Printer-friendly Version

Interactive Discussion



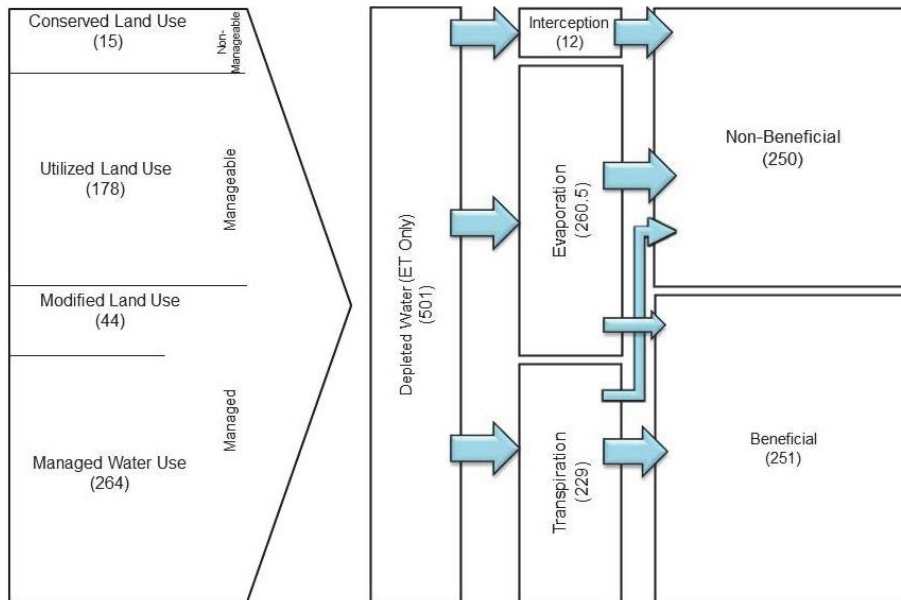

Fig. 3. WA+ consumptive use sheet for the Indus Basin based on 2007 data. All components are in km³.

Basin-wide water accounting using remote sensing data

P. Karimi et al.

Title Page

Abstract

Introduction

Conclusions

References

Tables

Figures

◀

▶

◀

▶

Back

Close

Full Screen / Esc

Printer-friendly Version

Interactive Discussion



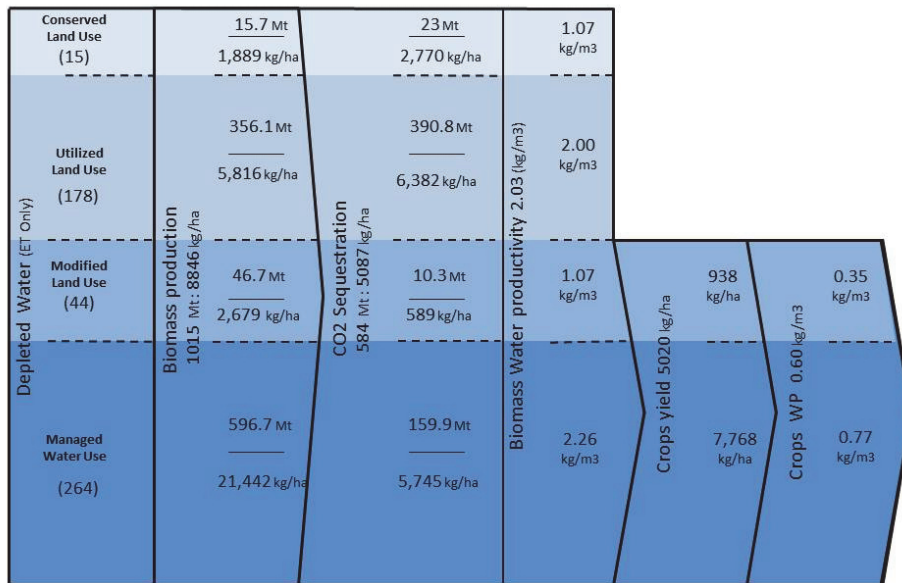

Fig. 4. WA+ productivity sheet for the Indus basin pertaining to the year 2007. Water use figures are in km³.

Basin-wide water accounting using remote sensing data

P. Karimi et al.

Title Page

Abstract Introduction

Conclusions References

Tables Figures

◀ ▶

◀ ▶

Back Close

Full Screen / Esc

Printer-friendly Version

Interactive Discussion



Basin-wide water accounting using remote sensing data

P. Karimi et al.

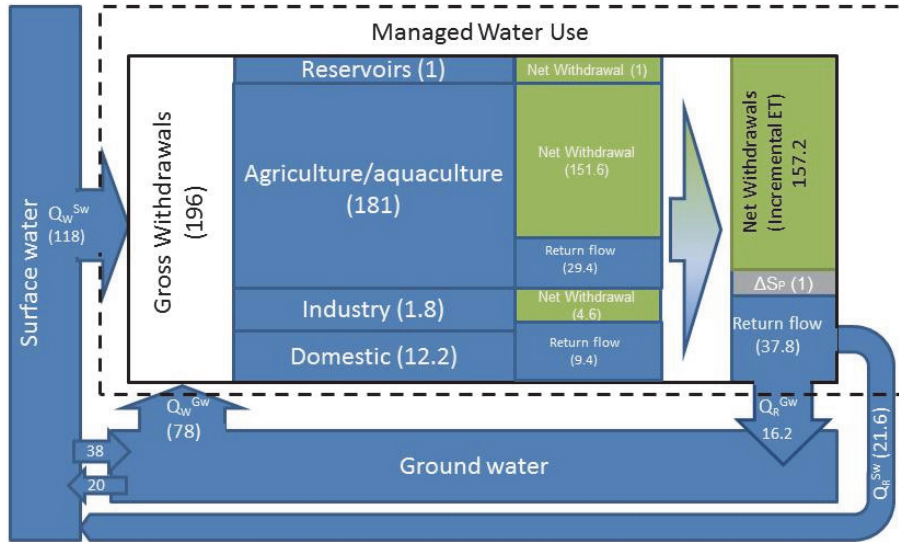

Fig. 5. WA+ withdrawal sheet for the Indus basin based on 2007 data. All components are in km³.

Title Page

Abstract Introduction

Conclusions References

Tables Figures

◀ ▶

◀ ▶

Back Close

Full Screen / Esc

Printer-friendly Version

Interactive Discussion



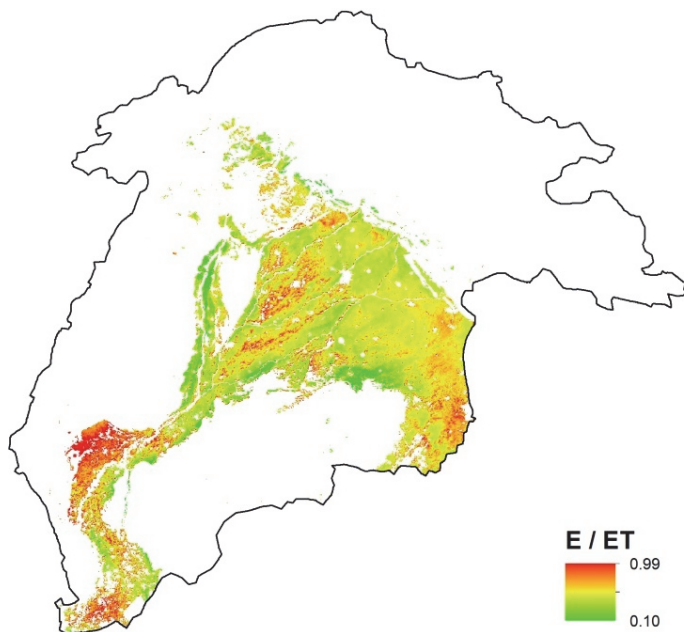

Fig. 6. Ratio of E over ET in irrigated areas of the Indus basin.

Basin-wide water accounting using remote sensing data

P. Karimi et al.

Title Page

Abstract

Introduction

Conclusions

References

Tables

Figures

◀

▶

◀

▶

Back

Close

Full Screen / Esc

Printer-friendly Version

Interactive Discussion



Basin-wide water accounting using remote sensing data

P. Karimi et al.

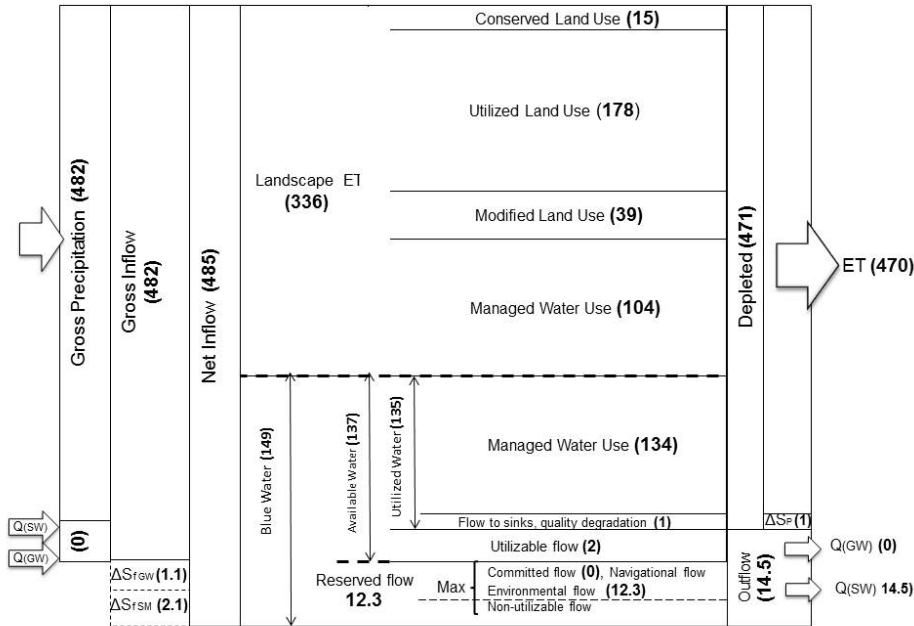

Fig. 7. Impact of scenario B on WA+ resource base sheet for the Indus. All components are in km^3 .

Title Page

Abstract

Introduction

Conclusions

References

Tables

Figures

◀

▶

◀

▶

Back

Close

Full Screen / Esc

Printer-friendly Version

Interactive Discussion

